

Errata

Title & Document Type: 1007A and 1008A Testmobiles Operating Note

Manual Part Number: 5958-5594

Revision Date: June 1986

About this Manual

We've added this manual to the Agilent website in an effort to help you support your product. This manual provides the best information we could find. It may be incomplete or contain dated information, and the scan quality may not be ideal. If we find a better copy in the future, we will add it to the Agilent website.

HP References in this Manual

This manual may contain references to HP or Hewlett-Packard. Please note that Hewlett-Packard's former test and measurement, life sciences, and chemical analysis businesses are now part of Agilent Technologies. The HP XXXX referred to in this document is now the Agilent XXXX. For example, model number HP8648A is now model number Agilent 8648A. We have made no changes to this manual copy.

Support for Your Product

Agilent no longer sells or supports this product. You will find any other available product information on the Agilent Test & Measurement website:

www.agilent.com

Search for the model number of this product, and the resulting product page will guide you to any available information. Our service centers may be able to perform calibration if no repair parts are needed, but no other support from Agilent is available.



Agilent Technologies



OPERATING NOTE/JUNE 1986

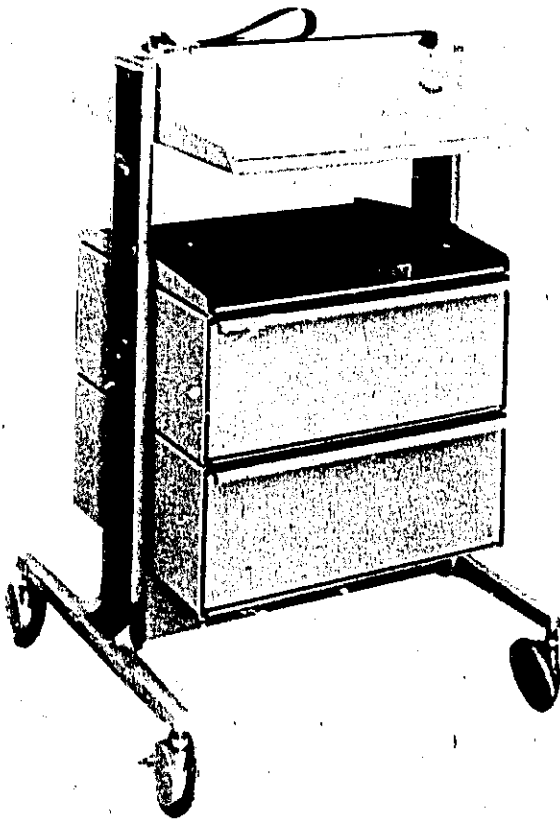

*Figure 1. Model 1008A
(Shown With Option 007 Installed)*

1. DESCRIPTION

2. Hewlett-Packard Models 1007A and 1008A Testmobiles provide convenient portability for your oscilloscope and other test equipment. The top mounting trays are table-top height and can be tilted in 10° increments for easy viewing. The nylon tie-down strap holds the instrument securely in place, and the side rail caps can hold three HP probes each. Both models have casters with mar-resistant rubber tires (locks are provided on front casters). Model 1008A is shown in figure 1.

3. The Model 1007A is designed for use with any instrument up to 315 mm (12-3/8 in.) wide and 508 mm (20 in.) long. The Model 1008A is designed for use with any instrument up to 483 mm (19 in.) wide and 508 mm (20 in.) long. The height of an instrument on either model must not exceed 330 mm (13 in.). Specifications for both models are listed in table 1.

4. ACCESSORIES AVAILABLE.

5. The following accessories are available for the Model 1008A:

- Rack Mount Kit 133 mm (5-1/4 in.) high
(HP Part No. 01008-68703).
- Rack Mount Kit 178 mm (7 in.) high
(HP Part No. 01008-68704).

6. OPTIONS.

7. Standard options (see figure 2) are installed at the factory and are available on request. Drawer options have a hasp on the rear so the drawer can be padlocked (lock not supplied). all shelves and cabinets are equipped with rubber mats. See table 5 for field installed option kit part numbers.

8. INITIAL INSPECTION AND CLAIMS.

9. Check the testmobile for damage. If damage is found, notify the carrier and the nearest Hewlett-Packard Sales/Service Office. HP will arrange for repair or replacement without waiting for settlement of the claim with the carrier.

10. INSTRUMENT MOUNTING INSTRUCTIONS.

11. To mount an instrument on the testmobile, proceed as follows:

- a. Center instrument on tilt tray. Place front feet of instrument between front lip of tilt tray and aluminum stop bracket.
- b. Place tie-down strap over top of instrument.

NOTE

For instruments with a top handle or storage pouch, thread strap under the handle or storage pouch.

- c. Insert fastener loop in hook on side of tilt tray.

**Operating Note Part No. 5958-5594
Microfiche Part No. 5958-5595**

PRINTED IN U.S.A.



For more information, call your local HP sales office listed in the telephone directory white pages. Ask for the Electronic Instruments Department. Or write to Hewlett-Packard: U.S.A. - P.O. Box 10301, Palo Alto, CA 94303-0890. Europe - P.O. Box 999, 1180 AZ Amstelveen, The Netherlands. Canada - 8877 Goreway Drive, Mississauga, L4V 1M8, Ontario. Japan - Yokogawa-Hewlett-Packard Ltd., 3-29-21, Takano-Higashi, Suginami-ku, Tokyo 168. Elsewhere in the world, write to Hewlett-Packard Intercontinental, 3495 Deer Creek Road, Palo Alto, CA 94304.

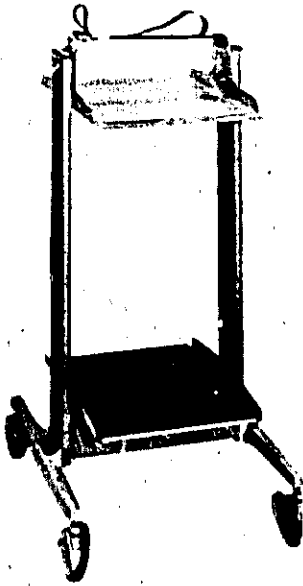

OPTION 001
Provides a lower shelf; load limit: 18 kg (40 lb).

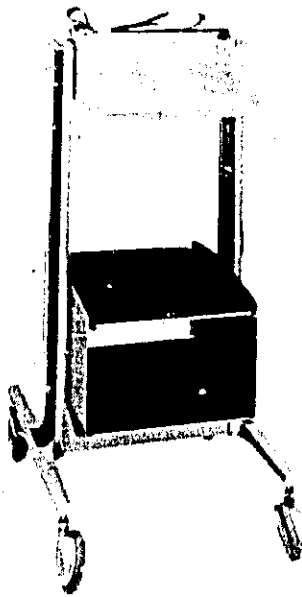

OPTION 002
Provides a lower cabinet and an upper shelf; load limit of each: 18 kg (40 lb).

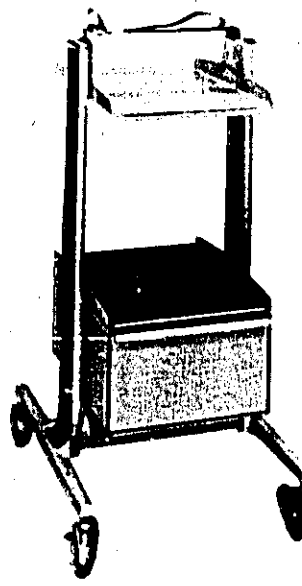

OPTION 003
Provides a cabinet with drawer and an upper shelf. Load limits: drawer, 11 kg (25 lb); shelf, 18 kg (40 lb).

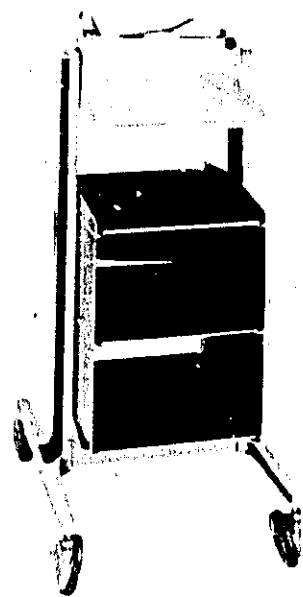

OPTION 004
Provides two cabinets and an upper shelf. Combined load limit of cabinets and shelf is 48 kg (105 lb).

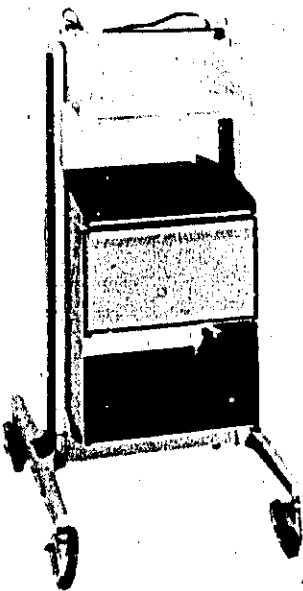

OPTION 005
Provides two cabinets with one upper drawer and shelf. Load limits: 18 kg (40 lb) in cabinet, 11 kg (25 lb) in drawer, and 18 kg (40 lb) on shelf.

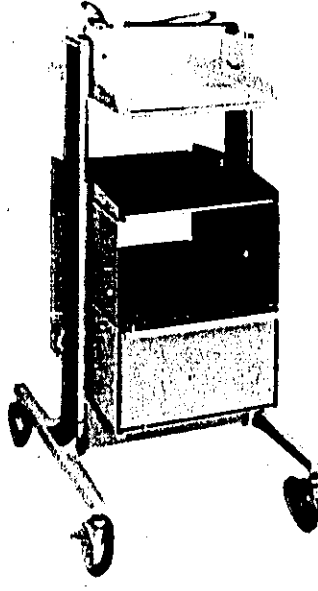

OPTION 006
Provides two cabinets with one lower drawer and an upper shelf. Load limits: same as Option 005.

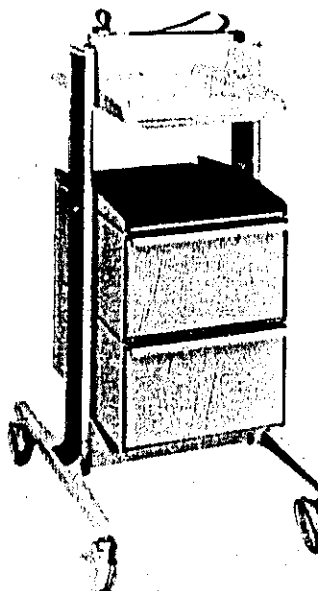

OPTION 007
Provides two cabinets with drawers and an upper shelf. Load limits: 11 kg (25 lb) in each drawer and 18 kg (40 lb) on shelf.

OPTION 008 (NOT ILLUSTRATED)
Provides five-outlet power strip on back of testmobile. May be mounted on cabinet or drawer assembly on Options 001 through 007, or on instrument tray of all versions. Power strip has USA 120 Vac power cord.

Figure 2. Standard Options

Table 1. Specifications

Dimensions: See dimensional drawing below.
Wheel Size: 102-mm (4 in.) diameter; locks on front wheels.
Weight: 1007A: 11 kg (25 lb); 1008A: 13 kg (29 lb).
Tilt Angle of Tray: -30° to +30° in 10° steps.

Load Limits of Tray: 1007A, 34 kg (75 lb); 1008A, 45.4 kg (100 lb). If rack mounts are used on 1008A, load limits are 27 kg (60 lb) on tilt tray and 18 kg (40 lb) on rack mounts. For option load limits see figure 2.

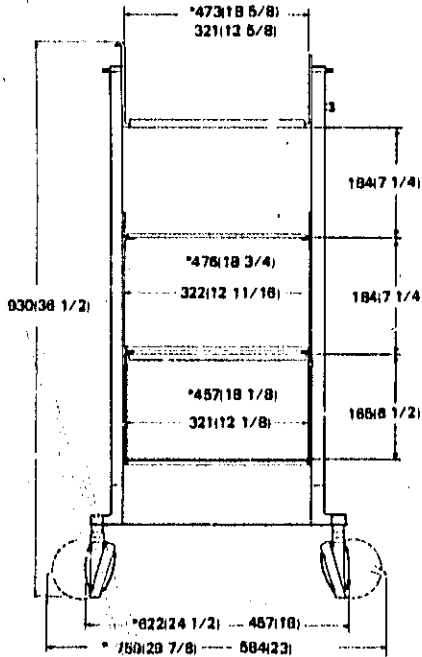

MODEL 1007A FRONT VIEW
*** MODEL 1008A FRONT VIEW**

NOTE
 DIMENSIONS IN
 MILLIMETRES AND
 (INCHES)

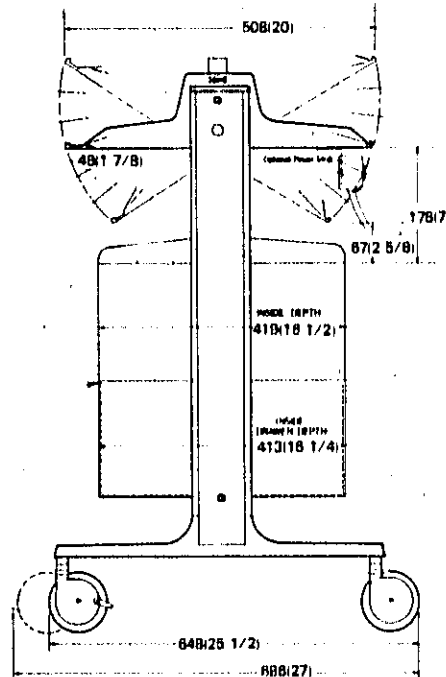

MODELS 1007A and 1008A SIDE VIEW

d. Hold fastener in hook and thread strap through fastener as shown in figure 3.

e. Take up excess strap by pulling free end. Allow some slack (about width of your index finger) on instrument edge nearest fastener.

f. Close fastener as shown in figure 3.

CAUTION

Do not force fastener closed; the tray can be bent so that the dent pin will not engage properly. If it is difficult to close, allow slightly more slack. When adjusted properly, little effort is required to close fastener.

12. OPERATING TILT TRAY.

13. Hold front of tilt tray, pull tray release knob, select any one of seven tray positions, and release the knob. Make certain the shaft connected to the knob engages one of the holes in the tray.

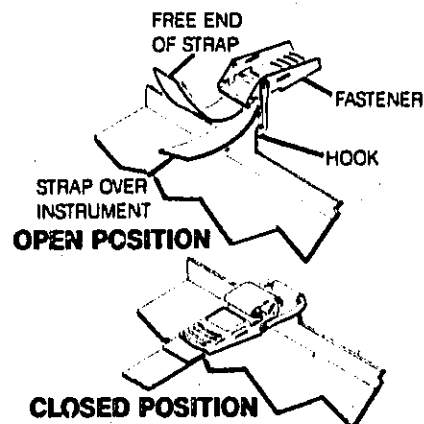

NOTE: OPEN FASTENER TO LACE AND ADJUST STRAP;
 CLOSE FASTENER TO TIGHTEN STRAP

Figure 3. Tie-down Strap Threading Diagram

14. REPLACEABLE PARTS.

15. Replaceable parts are shown in figures 4 and 5 and listed in table 2. To order a replacement part, address order to the nearest Hewlett-Packard Sales/Service Office, and specify the HP part number for each part. To order a part not listed in table 2, specify the testmobile model number and provide a description of the part, including function and location on the testmobile.

Table 2. Replaceable Parts

Reference Designation	HP Part No.	Description	Qty
HARDWARE			
H1	2510-0045	SCREW-MACH 8-32 .375-IN-LG PAN-HD-POZI	1
H2	2360-0113	SCREW-MACH 6-32 .25-IN-LG PAN-HD-POZI	3 (1007A) 5 (1008A) } NOTE 1
H3	2680-0105	SCREW-MACH 10-32 .625-IN-LG PAN-HD-POZI	2
H4	1460-0676	SPRING-CPRSN .24-IN-OD .5-IN-OA-LG SST	1
H5	2680-0067	SCREW-MACH 10-32 1.25-IN-LG PAN-HD-POZI	2
H6	3020-0024	SCREW-SKT HD CAP 5/16-18 3-IN-LG ALY STL	4
H7	3020-0019	SCREW-SKT HD CAP 5/16-18 1-IN-LG ALY STL	4
H8	2190-0894	WASHER-FL NON-METAL .312-IN-ID .094-IN-THK	2
H9	2190-0459	WASHER-FL NON-METAL .312-IN-ID .031-IN-THK	2
H10	2510-0111	SCREW-MACH 8-32 .75-IN-LG PAN-HD-POZI	2
H11	2190-0009	WASHER-LK INTL T NO. 8 .168-IN-ID	2
H12	3050-0662	WASHER-FL MTLN NO. 10 .213-IN-ID	2
H13	0590-1115	NUT-CHANNEL 8-32-THD .5-WD STL	2
H14	2360-0182	SCREW-MACH 6-32 .312-IN-LG PAN-HD-POZI	} SEE TABLE 3
H15	2510-0133	SCREW-MACH 8-32 .188-IN-LG PAN-HD-POZI	
H16	2190-0017	WASHER-LK HLCL NO. 8 .168-IN-ID	} OPTION 008 ONLY
H17	2360-0190	SCREW-MACH 6-32 .188-IN-LG 100 DEG	
H18	2680-0128	SCREW-MACH 10-32 .25-IN-LG PAN-HD-POZI	2
H19	3050-0002	WASHER-FL MTLN NO. 10 .203-IN-ID	2
H20	2190-0012	WASHER-LK EXT T NO. 10 .195-IN-ID	2
MECHANICAL PARTS			
MP1*	01007-03703	SIDE RAIL	2
MP2*	01007-26104	STOP PIN	1
MP3*	01007-04117	TILT TRAY 1007A	1
	01008-04122	TILT TRAY 1008A	1
MP4	01007-04102	BRACKET, INSTRUMENT STOP 1007A	1
	01008-04102	BRACKET, INSTRUMENT STOP 1008A	1
MP5	1530-2054	TIE DOWN ASSEMBLY	1
MP6	5040-8300	CAP, SIDE RAIL	2
MP7*	01007-26105	DETENT PIN	1
MP8*	01007-27201	TRIM, SIDE RAIL	2
MP9	0370-2578	KNOB, DETENT	1
MP10	5020-8110	FOOT	2
MP11	01007-20502	STRUT, 13-IN 1007A	1
	01008-20502	STRUT, 19-IN 1008A	1
MP12	1490-0974	CASTER, FRONT LEFT WITH BRAKE	1
MP13	1490-0975	CASTER, FRONT RIGHT WITH BRAKE	1
MP14	1492-0006	CASTER, BACK LEFT	1
MP15	1492-0007	CASTER, BACK RIGHT	1
MP16	01007-04114	CABINET, 13-IN 1007A	SEE TABLE 3
	01008-04117	CABINET, 19-IN 1008A	SEE TABLE 3

NOTE 1—ADDITIONAL QUANTITIES ARE USED ON OPTIONS 003, 005, 006, and 007. SEE TABLE 3.

* BEFORE ORDERING THESE PARTS SEE TABLE 4 ON PAGE 5.

Table 2. Replaceable Parts (Cont'd)

Reference Designation	HP Part No.	Description	Qty
MP17	01007-04115	DRAWER FRONT 1007A	SEE TABLE 3
	01008-04119	DRAWER FRONT 1008A	SEE TABLE 3
MP18	01007-04105	DRAWER BOX 1007A	SEE TABLE 3
	01008-04109	DRAWER BOX 1008A	SEE TABLE 3
MP19	4320-0312	MAT, VINYL 13-IN 1007A	SEE TABLE 3
	4320-0313	MAT, VINYL 19-IN 1008A	SEE TABLE 3
MP20	01007-04113	SHELF, 13-IN 1007A	SEE TABLE 3
	01008-04116	SHELF, 19-IN 1008A	SEE TABLE 3
MP21	01007-04116	DRAWER BACK 13-IN 1007A	SEE TABLE 3
	01008-04120	DRAWER BACK 19-IN 1008A	SEE TABLE 3
MP22	01007-04109	DRAWER LOCK	SEE TABLE 3
MP23	01007-04108	DRAWER STOP	SEE TABLE 3
MP24	1494-0047	DRAWER SLIDE	SEE TABLE 3
MP25	1251-8691	POWER STRIP	1 OPTION 008
MP26	01007-04118	BRACKET, POWER STRIP	1 OPTION 008

Table 3. Part Quantities For Options 001 Through 007

PART	QUANTITIES						
	001	002	003	004	005	006	007
H2*	—	—	10	—	10	10	20
H14	4	12	12	20	20	20	20
H15	—	—	14	—	14	14	28
H16	—	—	8	—	8	8	16
H17	—	—	4	—	4	4	8
MP16	—	1	1	2	2	2	2
MP17	—	—	1	—	1	1	2
MP18	—	—	1	—	1	1	2
MP19	1	2	1	3	2	2	1
MP20	1	1	1	1	1	1	1
MP21	—	—	1	—	1	1	2
MP22	—	—	1	—	1	1	2
MP23	—	—	1	—	1	1	2
MP24	—	—	2	—	2	2	4

*QUANTITIES IN ADDITION TO THOSE USED ON STANDARD TESTMOBILE.

Table 4. Replaceable Parts For Earlier Versions of Testmobiles With Tray Detent Pin And Knob In Center Of Side Rail.

Reference Designation	HP Part No.	Description	Qty
MP1	01007-03702	SIDE RAIL	2
MP2	01007-26102	STOP PIN	1
MP3	01007-04101	TILT TRAY 13-IN 1007A	1
	01008-04101	TILT TRAY 19-IN 1008A	1
MP7	01007-26103	DETENT PIN	1
MP8	4040-1288	TRIM, SIDE RAIL	2

Table 5. 1007A/1008A Testmobile Kit Part Numbers

OPTION	DESCRIPTION	PART NO. 1007A	PART NO. 1008A
Option 001	Lower Shelf	01007-60010	01008-60008
Option 002	Lower Cabinet & an Upper Shelf	01007-60011	01008-60009
Option 003	Cabinet with Drawer & an Upper Shelf	01007-60012	01008-60015
Option 004	Two Cabinets & an Upper Shelf	01007-60013	01008-60010
Option 005	Two Cabinets with One Upper Drawer & Shelf	01007-60014	01008-60011
Option 006	Two Cabinets with One Lower Drawer and an Upper Shelf	01007-60015	01008-60012
Option 007	Two Cabinets with Drawers & an Upper Shelf	01007-60016	01008-60013
Option 008	Five-outlet Power Strip	01007-60017	01007-60017

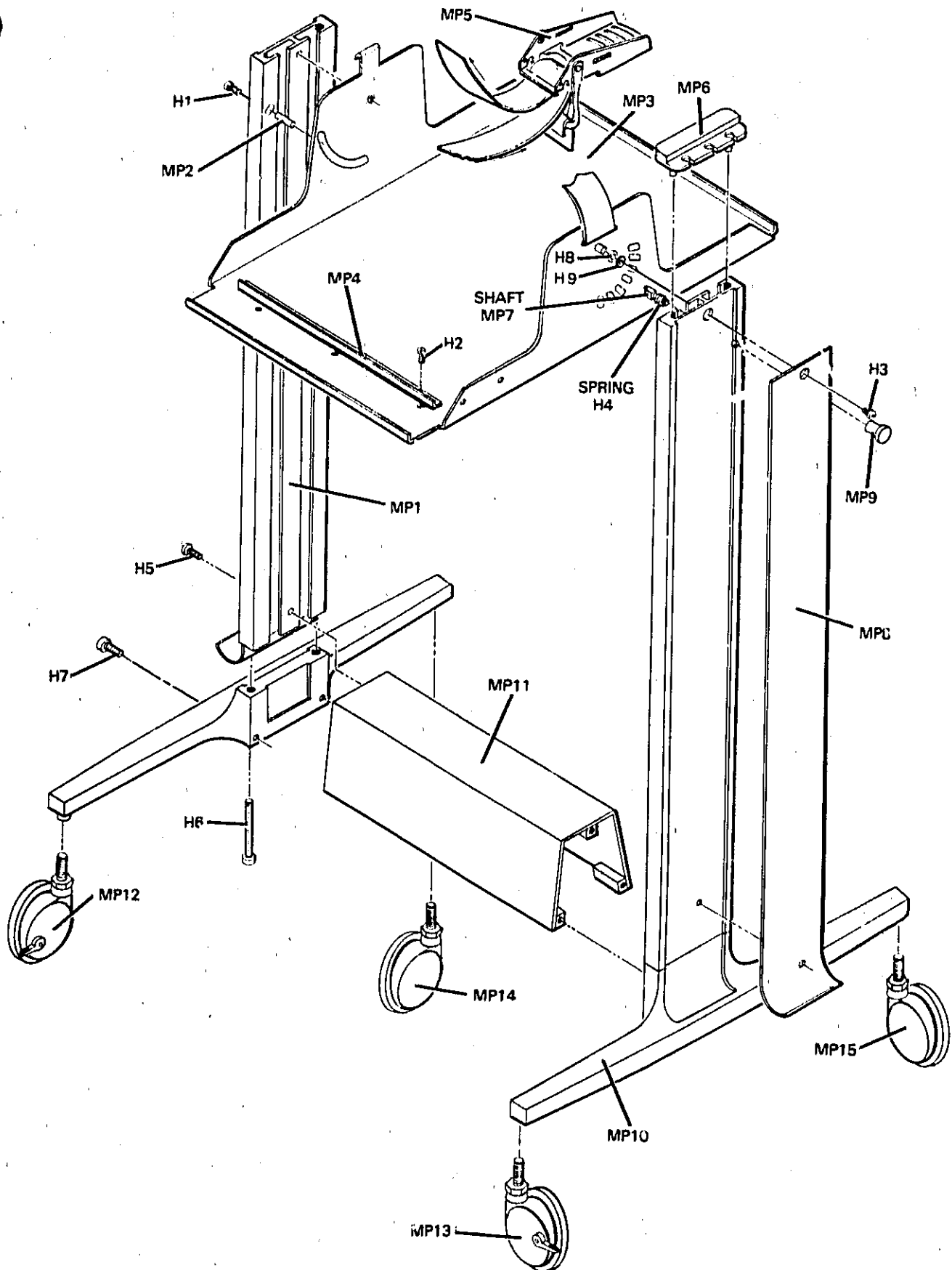

Figure 4. Replaceable Parts

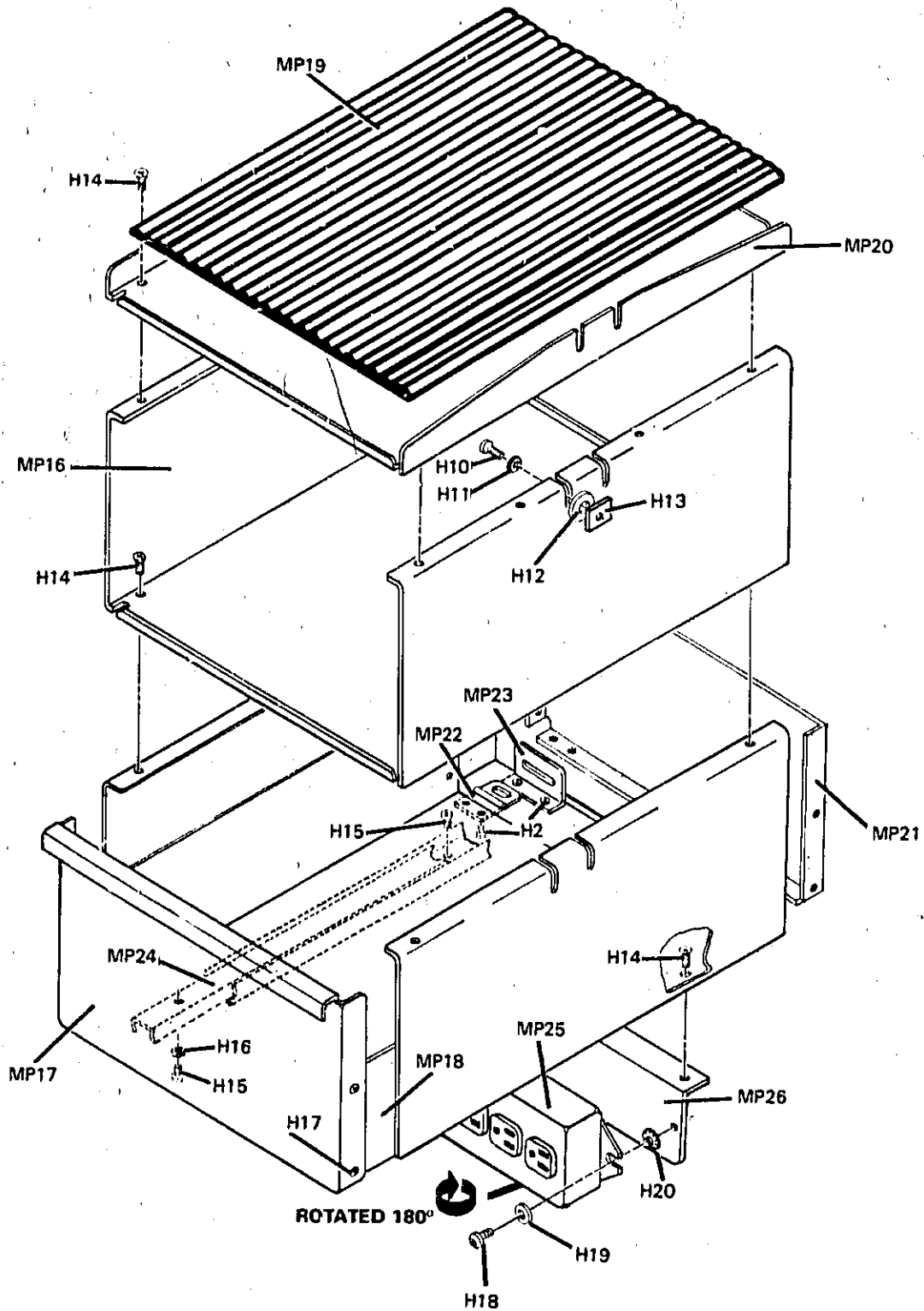

Figure 5. Option Parts